

Hybrid Inverter

META SERIES

6kW / 8kW



Operating
Manual

Default
Password
1234

CONTENTS

1. INTRODUCTION.....	1
1.1 SAFETY & WARNING.....	1
1.2 PRODUCT OVERVIEW.....	3
2. INSTALLATION INSTRUCTIONS.....	4
2.1 UNACCEPTABLE INSTALLATIONS.....	4
2.2 PACKING LIST.....	4
2.3 INSTALLATION.....	5
2.3.1 INSTALLATION LOCATION SELECTION.....	5
2.3.2 INSTALLATION.....	6
2.4 ELECTRICAL WIRING CONNECTION.....	8
2.4.1 PV CONNECTION.....	8
2.4.2 BATTERY CONNECTION.....	9
2.4.3 GRID & BACK-UP LOAD & GEN CONNECTION.....	11
2.5 SINGLE PHASE PARALLEL CONNECTION DIAGRAM....	17
3. TOUCHSCREEN USER MANUAL.....	21
3.1 MAIN PAGE.....	21
3.2 REAL-TIME INFORMATION PAGE.....	24
3.3 PASSWORD ENTER PAGE.....	26
3.4 SETTING PAGE.....	27
3.5 SYSTEM INFORMATION PAGE.....	27
3.6 SYSTEM SET PAGE.....	28
3.7 BATTERY SET PAGE.....	29
3.8 GRID SET PAGE.....	30
3.9 BASIC SET PAGE.....	30
3.10 ADVANCED SET PAGE.....	32
4. TROUBLESHOOTING.....	33
4.1 WARNING LIST.....	34
4.2 FAULT REFERENCE CODES.....	35
5. OTHERS.....	42
5.1 DISCLAIMER.....	42
5.2 TECHNICAL PARAMETERS.....	43

This series of products, also known as hybrid or bidirectional energy storage inverter, is suitable for solar systems in which PV, batteries, loads and grid systems participate together to achieve energy management.

The electric energy generated by the PV power generation system is used for self-consumption, the excess electric energy is used for battery charging, and the remaining electric energy is exported to the power grid.

When the PV power does not meet its own consumption, the battery will discharge to support the load operation. If the battery power is insufficient, the system will obtain power from the grid to support the load operation PV energy storage system architecture.

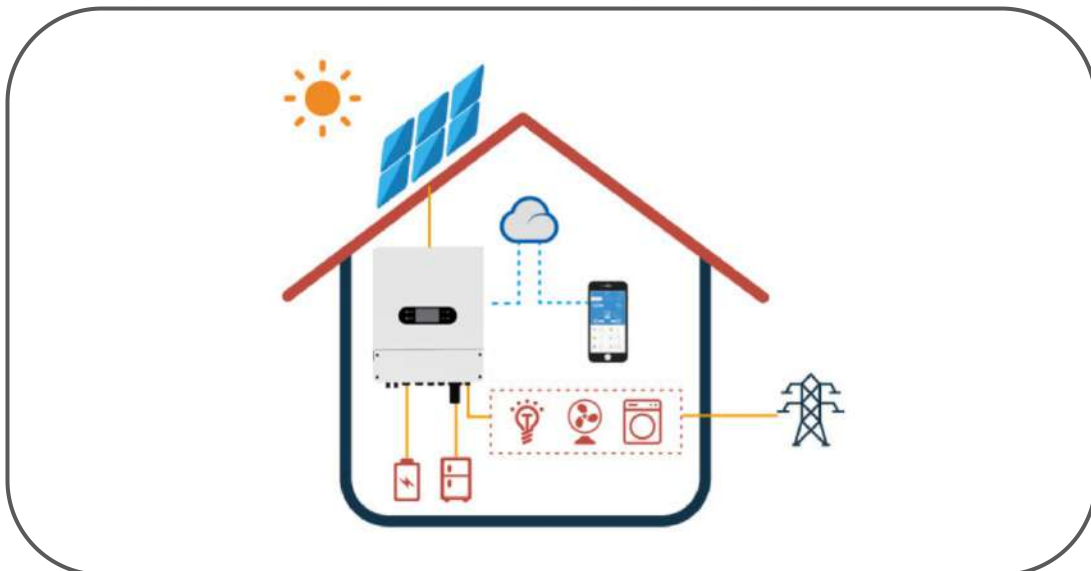







1.1 SAFETY & WARNING

Please read and follow all the instructions and cautions on the inverter or user manual during installation, operation or maintenance, as any improper operation might cause personal or property damage.

• SYMBOLS EXPLANATION

	Caution! Failing to observe a warning indicated in this manual may result in injury.
	Danger of electric shock due to high voltage! Disconnect all incoming power and turn off the product before working on it.
	Danger on hot surfaces! High-temperature hazard. Do not touch the product under operation to avoid being burnt.

	This side up! The package must always be transported, handled and stored in such way that the arrows always point upwards.
	Product should not be disposed as household waste. Do not dispose of the inverter as household waste. Discard the product in compliance with local laws and regulations .or send it back to the manufacturer.
	Grounding mark.
	Read through the user manual before any operations.
	Keep dry! The package/product must be protected from excessive humidity and must be stored under cover.
	Inverter will be touchable or operable after minimum 5 minutes of being turned off or totally disconnected, in case of any electrical shock or injury.

• SAFETY WARNING

Any installation and operation on inverter must be performed by qualified electricians, in compliance with standards, wiring rules or requirements of local grid authorities or companies.

Before any wiring connection or electrical operation on inverter, all DC and AC power must be disconnected from inverter for at least 5 minutes to make sure inverter is totally isolated to avoid electric shock.

The temperature of inverter surface might exceed 60 °C during working, so please make sure it is cooled down before touching it, and make sure the inverter is untouchable for children.

Do not open inverter cover or change any components without authorization, otherwise the warranty commitment for the inverter will be invalid.

Usage and operation of the inverter must follow instructions in this user manual, otherwise the protection design might be useless and warranty for the inverter will be invalid.

Appropriate methods must be adopted to protect inverter from static damage. Any damage caused by static is not warranted by manufacturer.

PV negative (PV-) on inverter side is not grounded as default design.







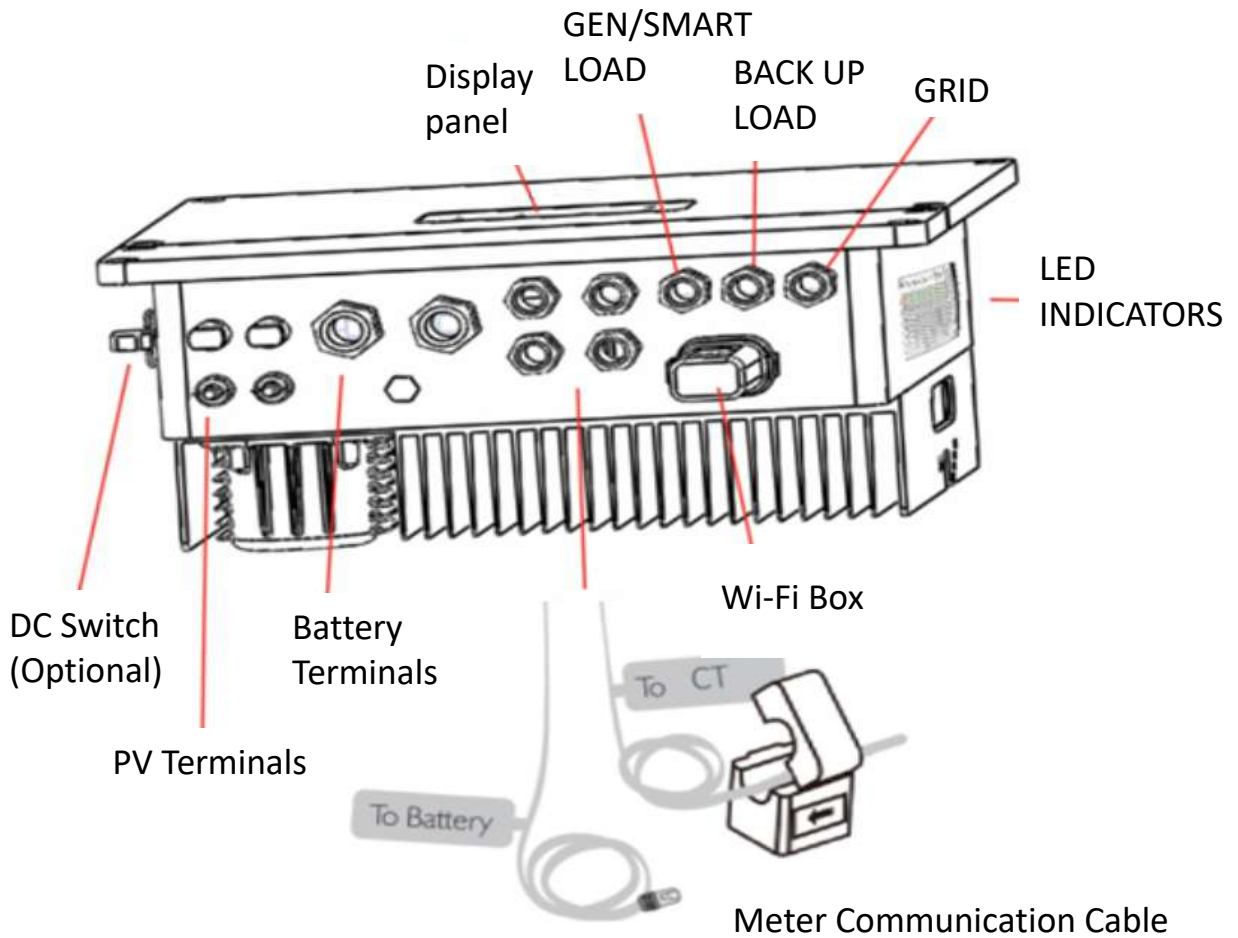









The total open-circuit voltage of the PV string/array should be lower than the maximum rated DC input voltage of the inverter. Any damage caused by PV over-voltage is beyond warranty.

When the inverter is working, it is prohibited to plug PV, battery, and AC connectors.

1.2 PRODUCT OVERVIEW

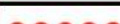

• LED INDICATORS

LED INDICATORS		
 SYSTEM		ON = SYSTEM IS READY
		BLINK = SYSTEM IS STARTING UP
		OFF = SYSTEM IS NOT OPERATING
 BACK-UP		ON = BACK-UP IS READY/POWER AVAILABLE
		BLINK = BACK-UP IS LOW
		OFF = BACK-UP IS OFF /NO POWER AVAILABLE
 COM		ON = BMS AND METER COMMUNICATION OK
		BLINK1 = METER COMMUNICATION OK BMS COMMUNICATION FAIL
		BLINK2 = BMS COMMUNICATION OK METER COMMUNICATION FAIL
		OFF = BMS AND METER COMMUNICATION FAIL
 FAULT		ON =FAULT HAS OCCURRED
		BLINK = OVERLOAD OF BACK-UP OUTPUT/ REDUCE LOAD
		OFF = NO FAULT

2

INSTALLATION INSTRUCTIONS

2.1 UNACCEPTABLE INSTALLATIONS

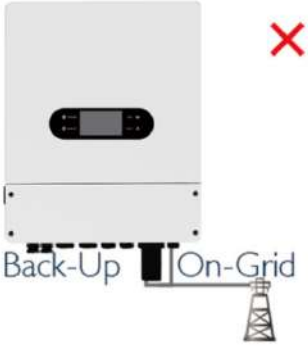
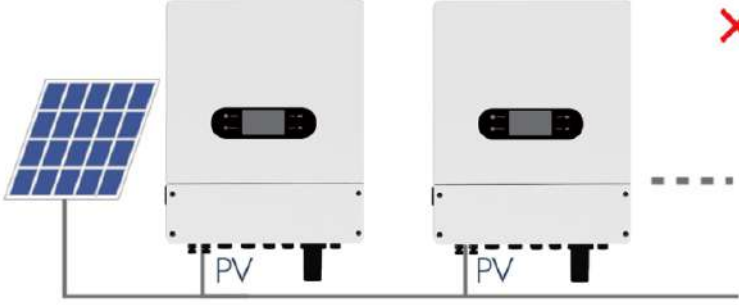

Please do not use the following installation methods that may cause damage to the system or inverter:

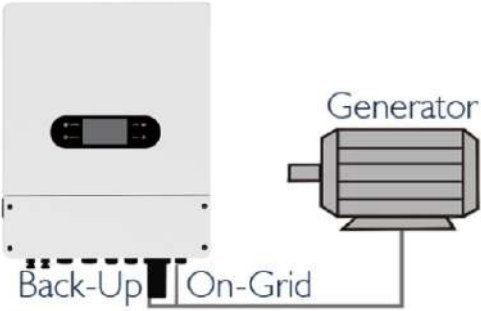
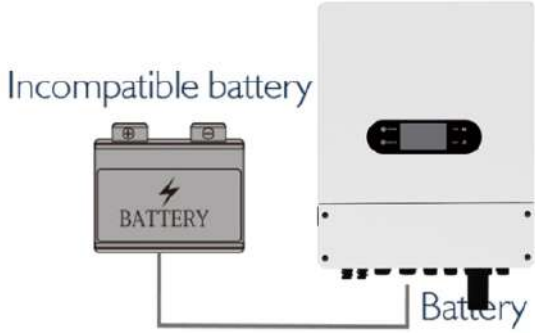



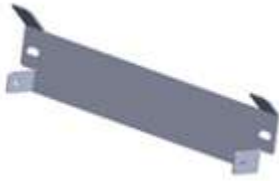

	
<p>BACK-UP SIDE CANNOT CONNECT TO GRID.</p>	<p>SINGLE PV STRING CANNOT CONNECT TO TWO OR MORE INVERTERS.</p>

	
<p>ON-GRID OR BACK-UP SIDE CANNOT CONNECT TO ANY AC GENERATOR.</p>	<p>CANNOT CONNECT TO INCOMPATIBLE BATTERIES.</p>

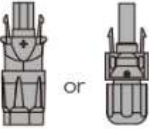
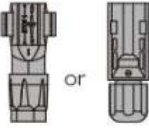
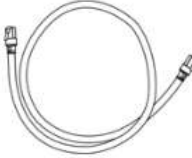
2.2 PACKING LIST

After receiving the inverter, please check to make sure all the components as below are not missing or broken.

			
<p>Inverter × 1</p>	<p>Wall-mounted Bracket I × 1</p>	<p>CT × 1</p>	<p>Data Collector × 1</p>

			
Positive DC Plug × 2	Negative DC Plug × 2	Net cable × 1	Battery terminal × 2
			
Expansion Bolts × 2	Hexagon head screw × 2	Cold terminals × 9	Hexagon head screw × 2

2.3 INSTALLATION

2.3.1 INSTALLATION LOCATION SELECTION

In order to facilitate the protection and maintenance of the inverter, the installation location of the inverter must be carefully selected according to the following rules:

Rule 1. The inverter should be installed on a solid surface that is suitable for the orientation of the inverter and capable of supporting the weight of the inverter.

Rule 2. The inverter should be installed vertically or at an angle not exceeding 15° .

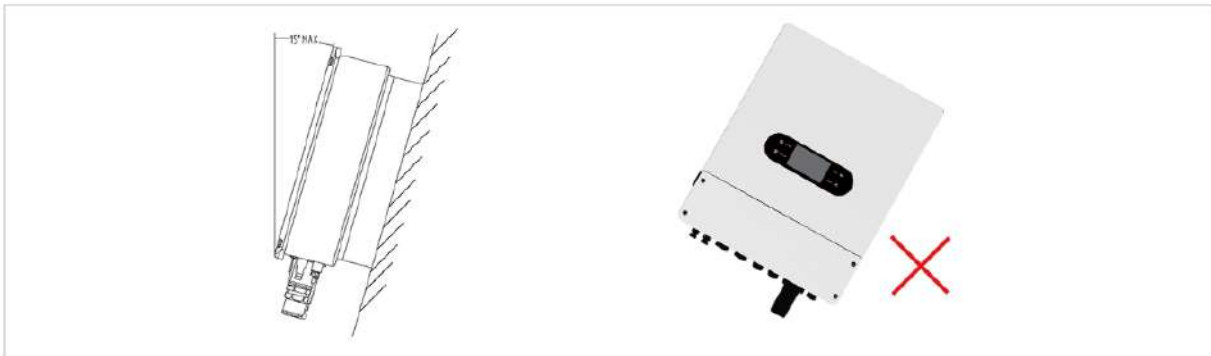

Rule 3. Ambient temperature should be lower than 60°C.

Rule 4. The installation of inverter should be protected under shelter from direct sunlight or bad weather like snow, rain, lightning etc.



Rule 5. Inverter should be installed at eye level for convenient maintenance.

Rule 6. Product label on inverter should be clearly visible after installation.

Rule 7. Leave enough space around inverter following the values on Picture 3.(as shown on the next Page)

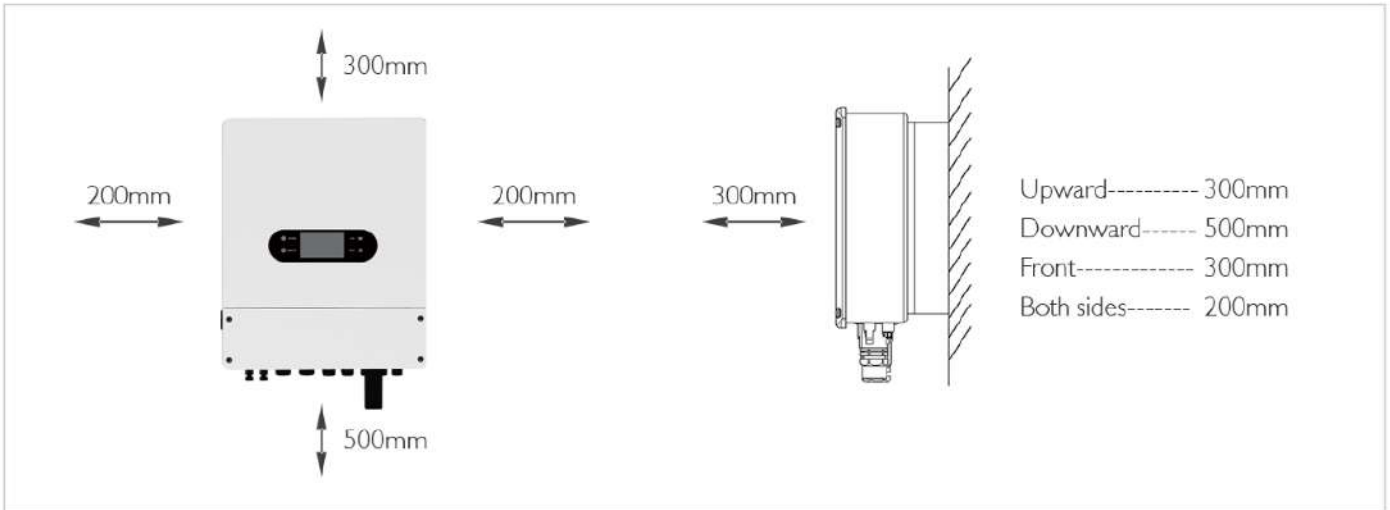

Inverter cannot be installed near flammable, explosive or strong electro-magnetic equipment.

2.3.2 INSTALLATION

This inverter can only be installed on a flat surface.

Step1:

Please use the mounting bracket as a template to drill 2 holes on right positions (10mm in diameter, and 35mm in depth)

Use the expansion screws in the accessory to secure the mounting bracket to the wall.

NOTE: Bearing capacity of the wall must be higher than 20KG, otherwise may not be able to keep inverter from dropping.

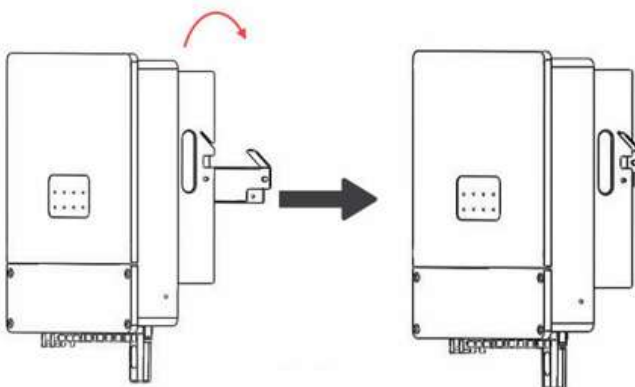
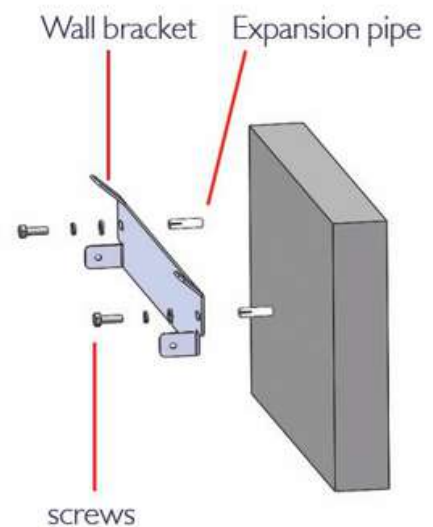

Step2:

Carry the inverter by grabbing the radiator on both sides and secure the inverter to the mounting bracket.

NOTE: Make sure the heat sink on inverter is rightly joint with mounting bracket.

Step3:

Finally, the screws are fixed, and an anti-theft lock can be added as needed.

NOTE: Make sure the screws between the inverter and the fixing plate are fixed tightly Prevent shedding.

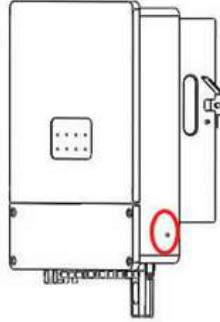
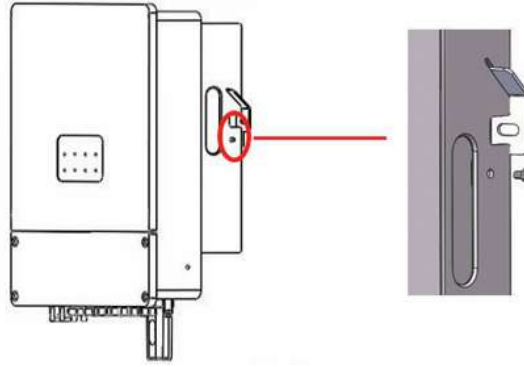

Step4:

The ground cable should be connected to the ground location on the side.

2.4 ELECTRICAL WIRING CONNECTION

2.4.1 PV CONNECTION

Before connecting PV panels/strings to inverter, please make sure requirements are followed as below :

- The total short-circuit current of PV string must not exceed inverter's max DC current
- The minimum isolation resistance to ground of the PV string must exceed 18.33k Ω in case of any shock hazard
- PV strings could not connect to earth/grounding conductor
- Use the DC plugs in the accessory box

NOTE: There will be MC4 or Amphenol DC plugs in accessory box, the detailed connection as below:

Step1: Prepare PV cables and DC plugs.

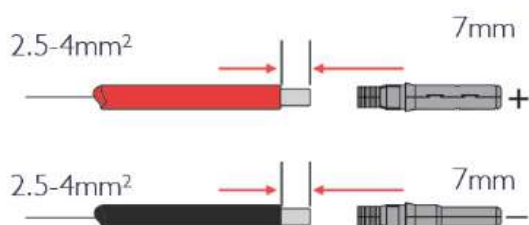

NOTE:

- Please use DC plugs and connectors in accessory box
- PV cable should be standard, 2.5-4mm² PV cable

Step2: Connect PV cable to DC connectors.

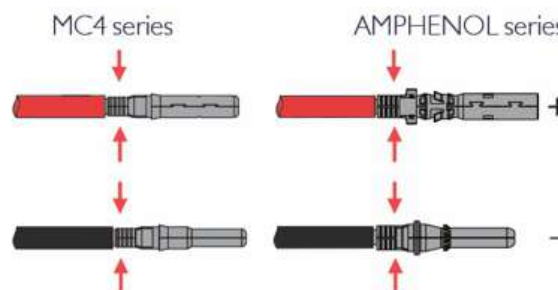

NOTE:

- PV cable must be tightly crimped into the Connectors.
- For Amphenol connector, the limit buckle cannot be pressed.

Step3: Screw the cap on and plug onto inverter side.

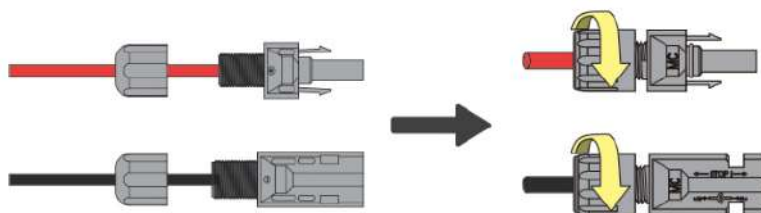

NOTE:

- There will be a click sound if connectors are inserted correctly into DC plugs



The polarity of the PV strings and the Inverter cannot be connected in reverse, otherwise the Inverter will be damaged and warranty will become void.

2.4.2 BATTERY CONNECTION

Applicable to lithium batteries (packs) whose capacity should be greater than or equal to 50Ah. Battery cable requirements are as follows:

	Grade	Description	Value
	A	OD	10-12mm
	B	Isolation section	NA
	C	Conductor Core	20-25mm ²

• Please be careful against any electric shock or chemical hazard

• **Battery wiring connection steps as below:**



Make sure battery switch is off and battery nominal voltage meet Hybrid inverter specification. Before connecting Battery to inverter make sure inverter is totally isolated from PV and AC power.

Step1: Prepare battery cables and accessories and put battery power cable through battery cover.

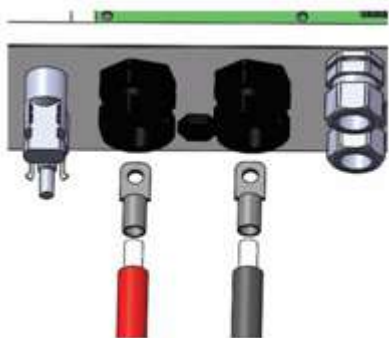

NOTE:

1. Please use accessories from box
2. Battery power cable should be 20~25mm²

Step2: Make battery terminals.

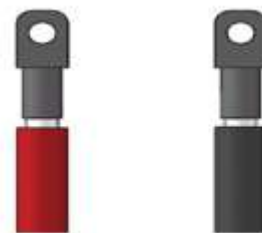

- Strip cable coat, revealing 10mm length of metal core
- Use special crimper to compress battery terminal tightly

Step3: Connect battery terminals onto inverter.

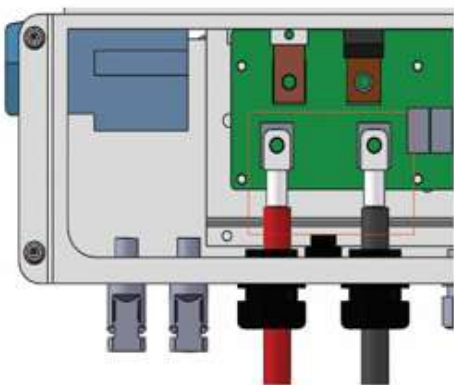

NOTE:

Please make sure polarity (+/-) of battery are not reversed

•FOR LEAD-ACID BATTERIES

Lead-Acid and other similar older-technology battery types require experienced and precise design, installation and maintenance to work effectively.

For lead-acid battery bank, the inconformity between battery cells might lead to battery cell over-charge or discharge, and might subsequently damage battery cells and shorten battery bank life.

For this Inverters there is no temperature compensation, thus customers need to set battery settings based on the real working temperature of battery.

For lead-acid battery settings on App, please refer to battery specifications and the actually battery working condition like working temperature and battery age. Unsuitable settings will lead to higher SOC deviation, weaker battery lifespan and further battery damage.

For lead-acid batteries, battery SOC calculation might not be accurate due to the battery inconformity between cells, battery aging or other specifications of lead-acid battery etc.

We will keep the right for explanation on all the settings suggested and all the problems happened on lead-acid batteries or the whole system. And we are not responsible for any damage caused by unsuitable settings, battery beyond warranty or battery quality etc.

•BATTERY PROTECTION DESCRIPTION

Battery will act a protective charge/discharge current limitation under any of the following condition as below:

- Battery SOC is lower than SOC Protection
- Battery voltage lower than discharge Cut-off Voltage
- Battery over temperature protection
- BMS limitation for lithium battery

When charge/discharge current limitation protection occurs:

- Under on-grid mode, battery charge/discharge operation could be abnormal
- Under off-grid mode, Back-Up supply will shut down

2.4.3 GRID & BACK-UP LOAD & GEN CONNECTION

An external AC switch (>32A) is needed for On-Grid connection to isolate from grid when necessary. Below are the requirements on AC switch use:

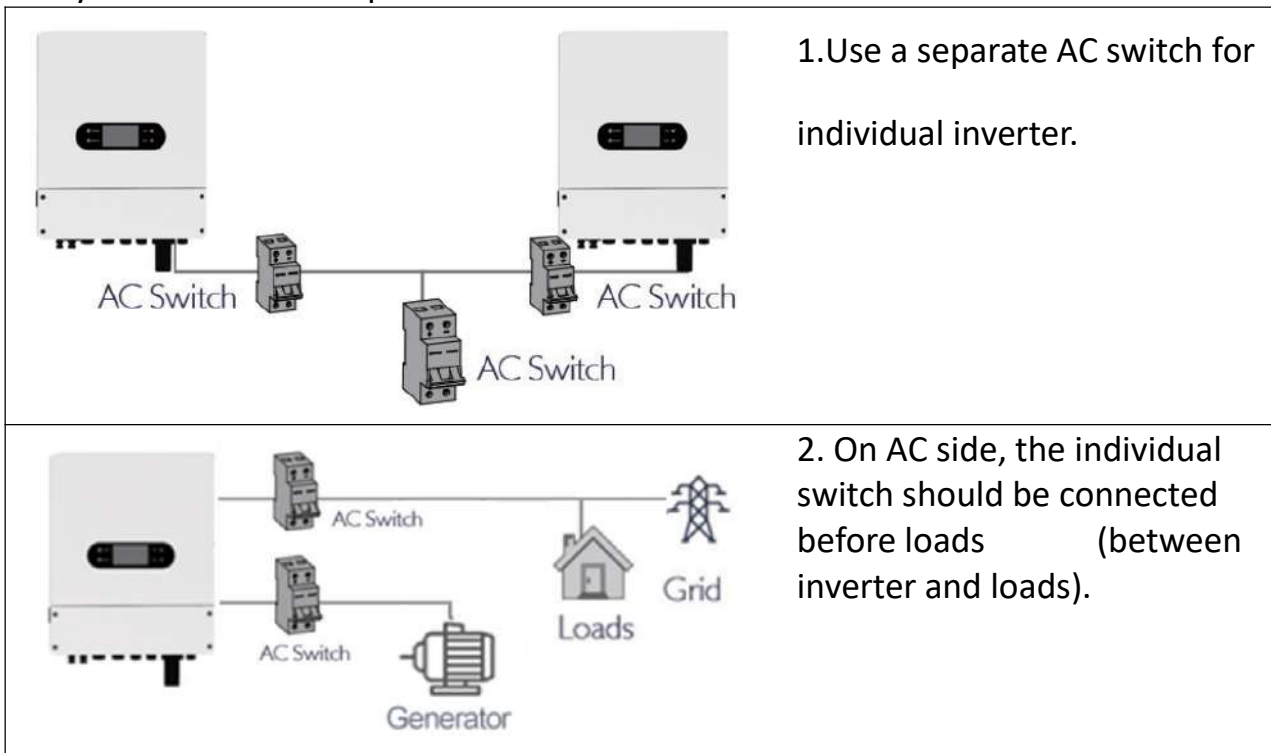

• Grid wiring connection process is as below:

	Make sure inverter is totally isolated from any DC or AC power before connecting AC Cable.
--	--

Step1:

1. Prepare the terminals and AC cables.
2. Put AC cable through terminal cover and screw the three cables tightly on the connectors.



4mm² Copper Conductor Material

NOTE:

- Please use the terminals in components box;
- Make sure cable jacket is not locked with conductor

Step2: Lock terminal cover and screw up the terminal cap

Note: Make sure the terminal cover is rightly locked onto the terminal

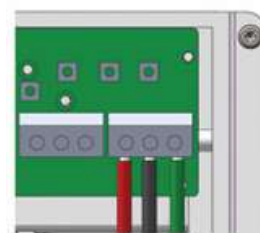

Step3 : Connect the assembled AC terminals onto inverter.

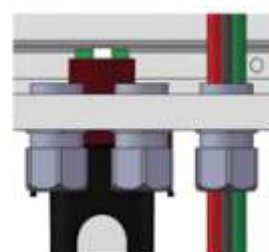

Note: Make sure it is connected to 'GRID' side

•**Back-Up wiring connection process is as below:**

An external AC switch (>32A) is needed for Back-Up connection to be isolated when necessary.

	The absence of AC breaker on Back-Up side will lead to inverter damage when an electrical short-circuit occurs on Back-Up side, and Back-Up function cannot turn off under on-grid condition.
---	---

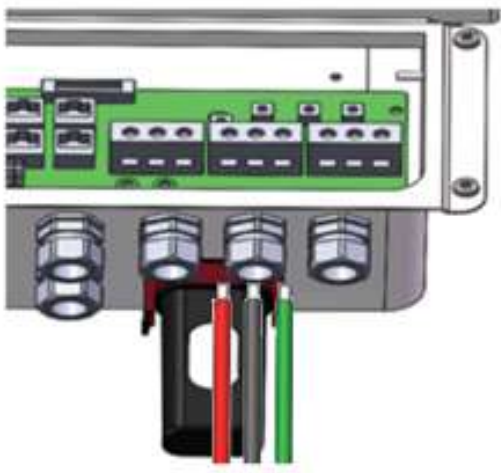
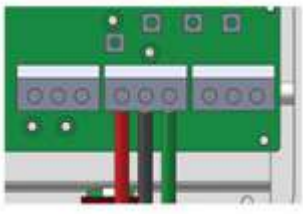
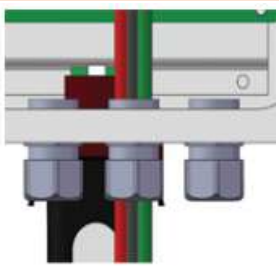
<p>Step1:</p> <ol style="list-style-type: none"> 1. Prepare the terminals and AC cables. 2. Put AC cable through terminal cover and screw the three cables tightly on the connectors.  <p>4mm² Copper Conductor Material</p> <p>NOTE:</p> <ul style="list-style-type: none"> • Please use the terminals in components box; • Make sure cable jacket is not locked with conductor 	<p>Step2:</p> <p>Lock terminal cover and screw up the terminal cap</p> <p>Note: Make sure the terminal cover is rightly locked onto the terminal</p> 
<p>Step3:</p> <p>Connect the assembled AC terminals onto inverter.</p>  <p>Note: Make sure it is connected to 'back-up' side</p>	

Declaration For Back-Up Loads

The inverter can continuously output twice the rated power within 15 seconds to ensure the operation of the backup load. If the operating temperature is too high, the inverter itself will disconnect the output.

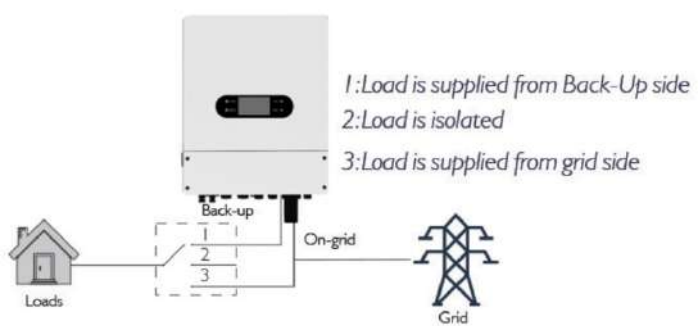
<p>For a convenient maintenance, a switch could be installed on Back-Up and On-Grid side. Then it is adjustable to support load by Back-Up or by grid or just leave it there</p>	 <p>1: Load is supplied from Back-Up side 2: Load is isolated 3: Load is supplied from grid side</p>
---	--

Declaration For Back-Up Overload Protection

When the overload protection function takes effect, the inverter will stop. At this time, you need to reduce the load and then operate the APP to "Overload Reset" or restart after a complete power outage.

•GEN wiring connection process is as below:

An external AC switch (>32A) is needed for Back-Up connection to be isolated when necessary.

	The absence of AC breaker on GEN side will lead to inverter damage when an electrical short-circuit occurs on Back-Up side.
--	---

Step1:
 1. Prepare the terminals and AC cables.
 2. Put AC cable through terminal cover and screw the three cables tightly on the connectors.

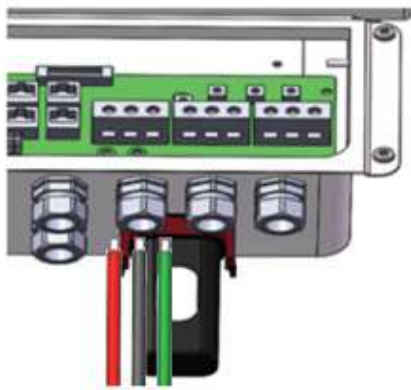

4mm² Copper Conductor Material

NOTE:

- Please use the terminals in components box;
- Make sure cable jacket is not locked with conductor

Step2:
 Lock terminal cover and screw up the terminal cap
Note: Make sure the terminal cover is rightly locked onto the terminal

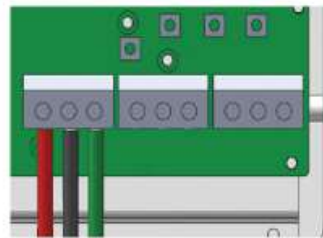

Step3:
 Connect the assembled AC terminals onto inverter.

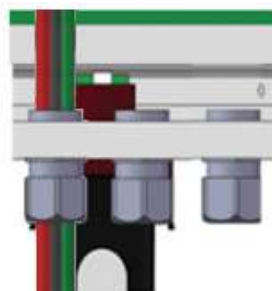

Note: Make sure it is connected to 'GEN' side

•GS Indications

GS: dry contact signal for Starting up the diesel generator.
 When the "GEN signal" is active, the open contact (GS) will switch on (no voltage output).

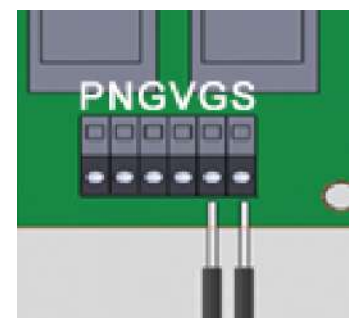
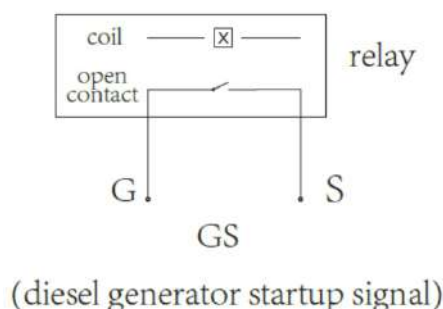



Note: When the Smart Load Output function is turned on, the GEN port can be used as an output port to connect to the load. Smart load output or generator input functions cannot be set simultaneously.

•CT Indications

	All work should be performed by trained and qualified operators using safe and suitable tools.
---	--

Since this product is a split type transformer, please pay attention to the cleanliness of the magnetic core surface during installation. If there is dirt on the core surface, the accuracy of the product will be deteriorated.

1. Before the transformer is connected to any equipment, please ensure that the circuit is powered off to prevent clicks.
2. Open CT, see figure 1.
3. Clip the CT on the cable under test. Make sure that the maximum current in the wiring does not exceed the maximum input current of the CT; The current flows in the direction of the arrow on the CT housing.
4. Fasten the CT again, the cable under test should be inside the CT window now (see figure 2)
5. Fix the CT on the cable under test with nylon cable ties to prevent the CT from sliding see figure 3)
6. Connect the CT output white wire to the positive terminal of the measuring device, and the CT output black wire to the negative terminal of the measuring device (see figure 4).
7. After checking that the circuit is correct, turn on the power and the CT starts to measure the current in the circuit.

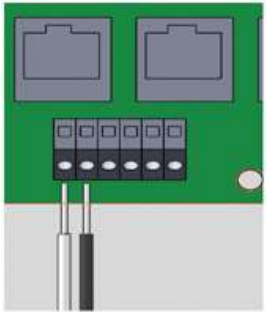
figure 1	figure 2	figure 3	figure 4
			

• WIRING SYSTEM FOR HYBRID INVERTER

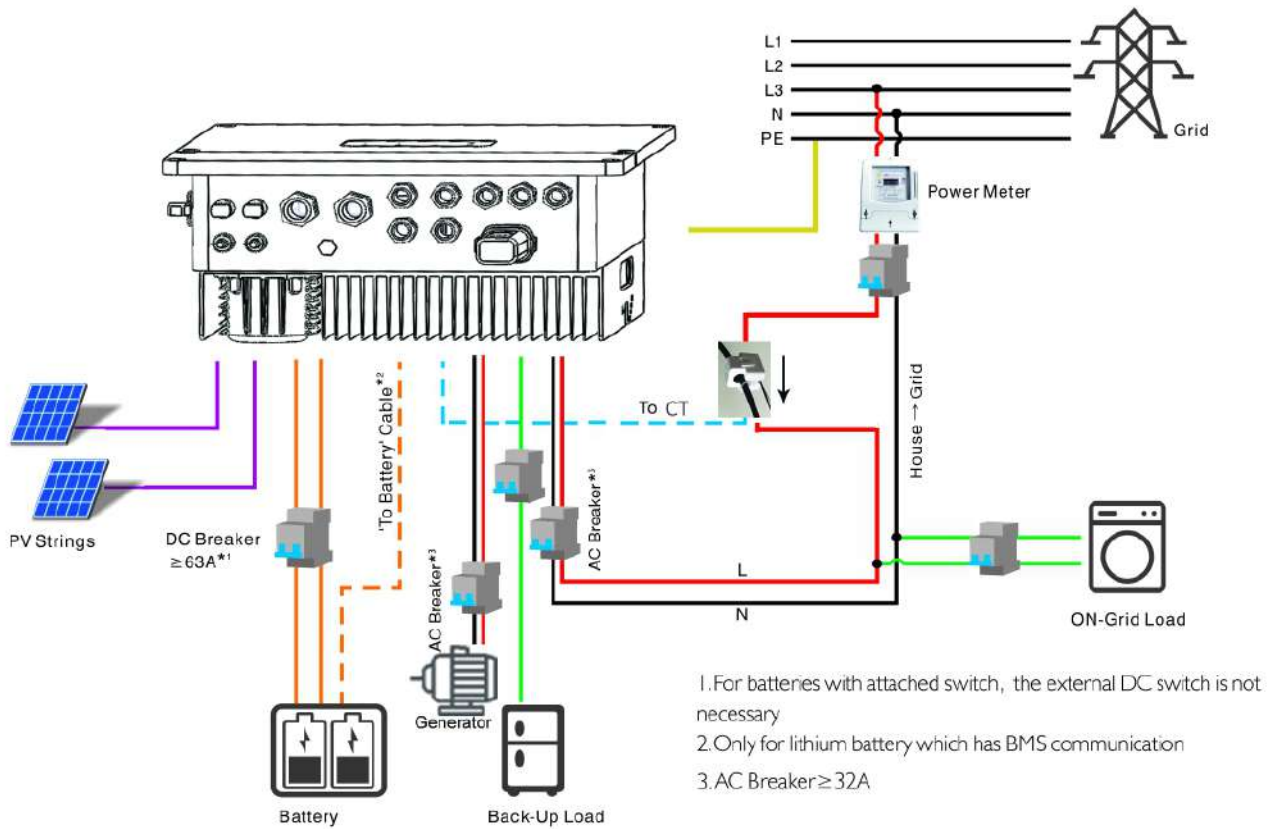

• SYSTEM CONNECTION DIAGRAMS

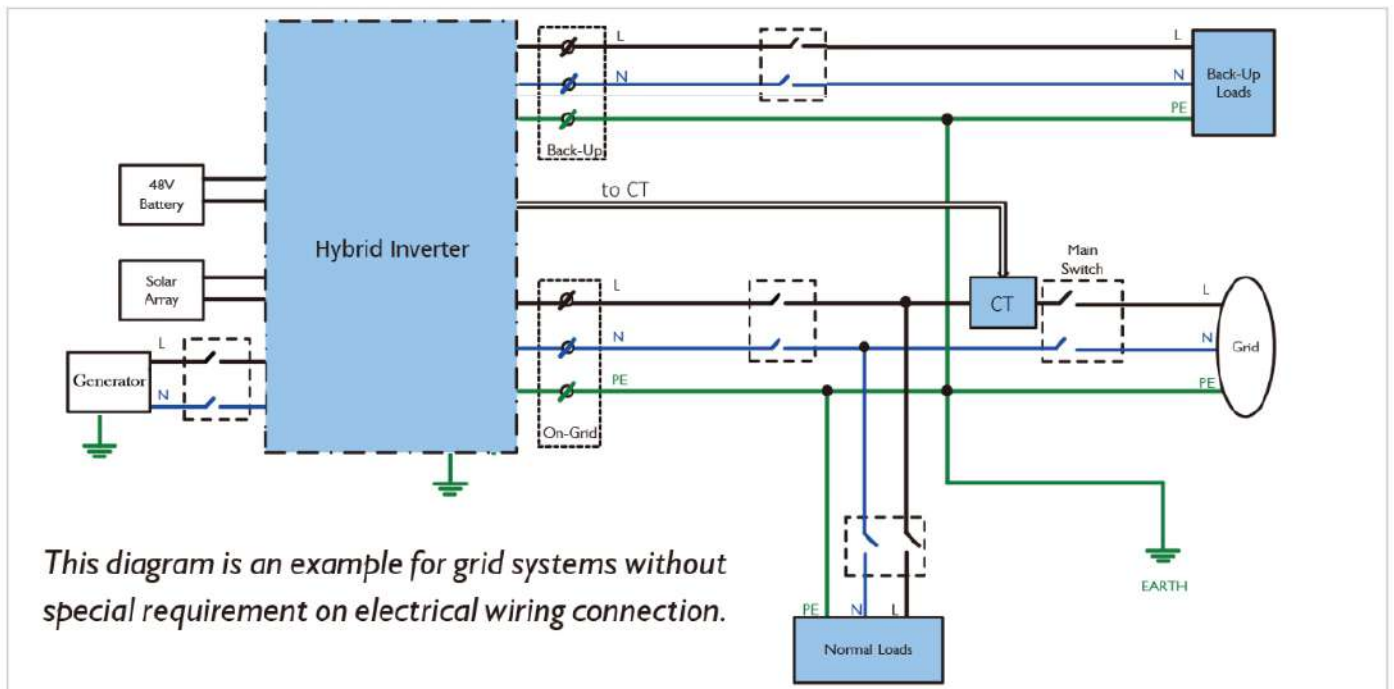

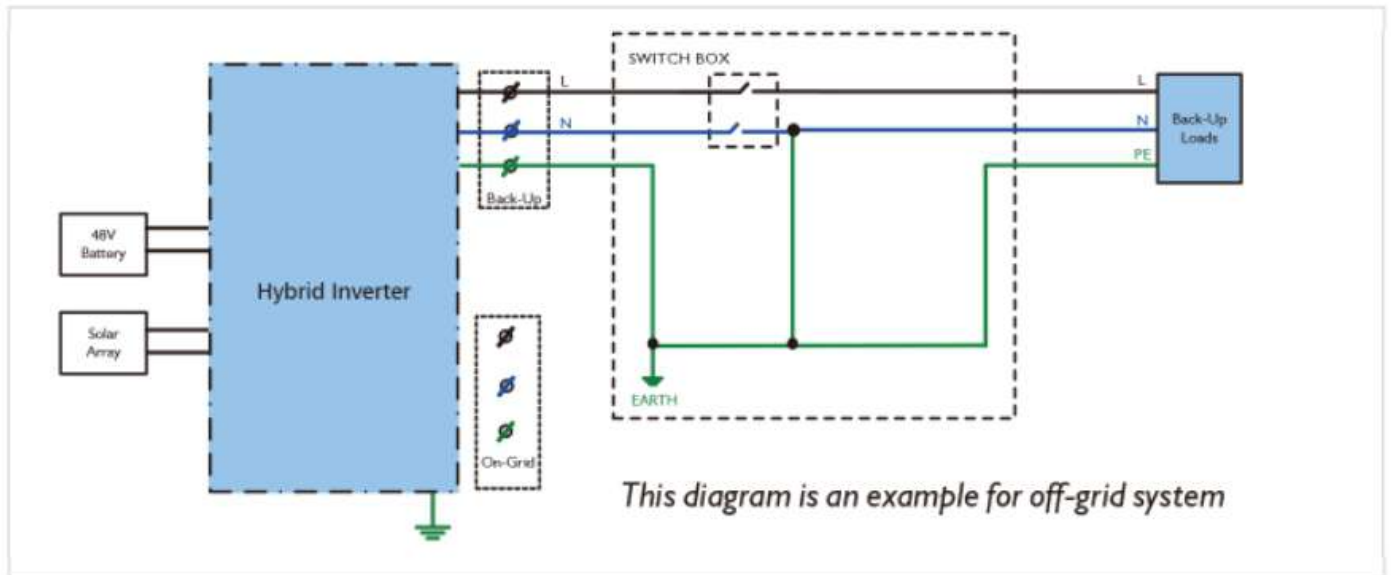

NOTE:

Meter communication cable (RJ45) is attached on the inverter "To Meter" cable, could be extended to max 100m, and must use standard RJ45 cable and plug as below:



Position	Color	BMS(CAN) Function	BMS(485) Function	Meter Function
1	Orange&white	NC	485_B	NC
2	Orange	NC	485_A	NC
3	Green&white	NC	NC	485_BI
4	Blue	CAN_H	NC	NC
5	Blue&white	CAN_L	NC	NC
6	Green	NC	NC	485_AI
7	Brown&white	NC	485_A	485_BI
8	Brown	NC	485_B	485_AI

2.5 SINGLE PHASE PARALLEL CONNECTION DIAGRAM

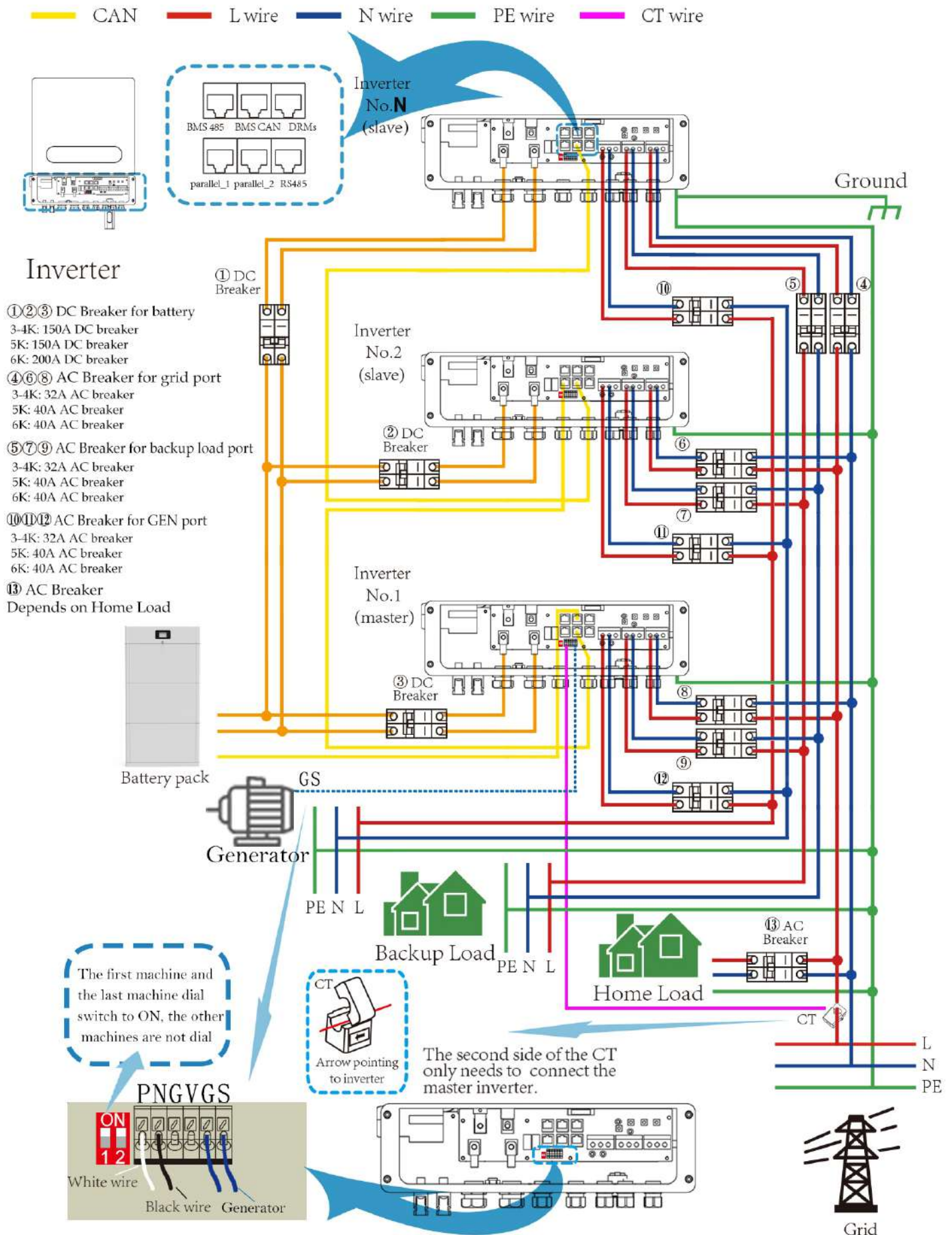

3.1 MAIN PAGE



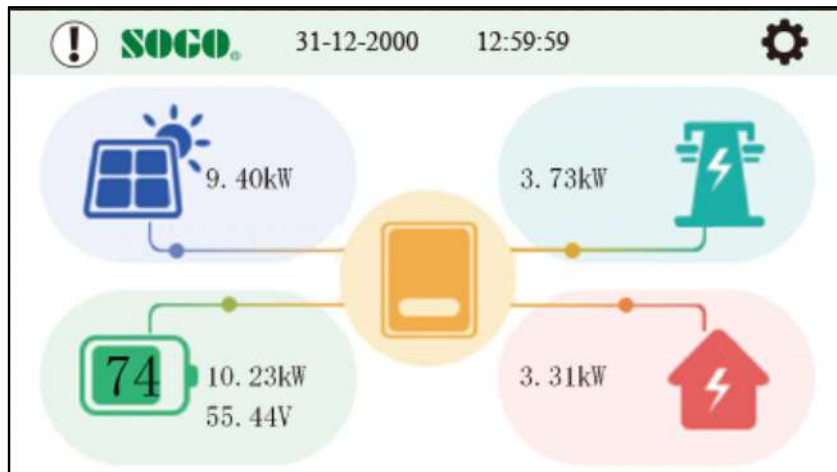



The LCD is a touch screen, please touch the screen to operate.

























This is the main page. Power on the LCD to show the flow chart on the main page. When powering on, data refreshing exists a little delay, so please wait for a few seconds before operation until the real time appears directly above on the screen.

The main page displays PV, grid, battery, load power, battery voltage and SOC. At the same time, the color of the inverter icon indicates the real time operation status. Based on the real-time power changes, the battery icon changes, and through the signal dots flow direction to show the dynamic flow of power relationship.

• Description of Touch Functions

Icons	Functions
	Click to enter the PV page, and view real-time data for the PV section.
	Click to enter the Grid page, and view real-time data for the Gird section.
	Click to enter the GEN page, and view real-time data for the GEN section.
	Click to enter the Battery page, and view real-time data for the Battery section.
	This icon means that the Battery SOC ranges from 0 to 10 percent.
	This icon means that the Battery SOC ranges from 10 to 20 percent.

	This icon means that the Battery SOC ranges from 20 to 30 percent.
	This icon means that the Battery SOC ranges from 30 to 50 percent.
	This icon means that the Battery SOC ranges from 50 to 75 percent.
	This icon means that the Battery SOC ranges from 75 to 100 percent.
	Click to enter the Load page, and view real-time data for the Load section.
	Click to enter the Run page, and overview the basic information of each section.
	If the icon is orange, it indicates current normal operation.
	If the icon is red, it means current alarm faults.
	Click to enter the Error Code page, and view the latest alarm records (up to 99). The content includes the number of messages, alarm time, and error code.
	Click to enter the Setting page, but you need to enter the password correctly at first.
	Home-return button.
	Back button.
	Page-up button.
	When the button turns transparent, it means untouchable.
	Page-down button.
	When the button turns transparent, it means untouchable.
	Save button.
	When the button turns transparent, it means untouchable.
	It indicates that the password is correct, click to enter the Setting page.
	It indicates the password is wrong and you need to re-enter, or it shows ERROR.
	It means unselected.
	It means selected.
	It means off.

☑	It means on.
---	--------------

Click on the icons of each section to view real-time data, as shown in the table above. Click on the gear icon in the upper right corner of the Main screen to enter the Setting interface. In order to protect the information security and prevent misuse, each time you enter the Setting interface, you need to enter the password once. The default password is 1234. There is a delay of a few seconds in the judgment of the password, please be patient and wait for the entry icon to turn on and change to green, click and enter Setting menu interface, select the system set, battery set, grid set, generator set, basic set, advanced set and others. Enter the sub-setting interface for parameter modification (If the password is wrong, the entry icon closes and turns red, you need to re-enter the correct password. If you click on the icon at this time, it will display "Error", you can only click on the home return button or back button to re-enter the password interface and enter the correct password).

In each sub-setting interface, the selection way is to click on the hollow circle to make it become a solid circle or click on the box to make the check mark appear, and the input way is to click on the rectangular input box to use the keyboard to input the numbers (there is no need to input the unit), and then click on save button to take effect. After successful setting, it will return back to the previous interface automatically. Any parameter modification needs to click save to take effect, otherwise the modification will not work. LCD brightness and standby time are adjusted by clicking the plus/minus icon or dragging the slider, and system time is adjusted by clicking the plus/minus icon. Similarly, you need to save after modification. The parameter settings have limited the range of input values to protect against accidental touch, so you can operate with peace of mind.

• Operation Flow Chart

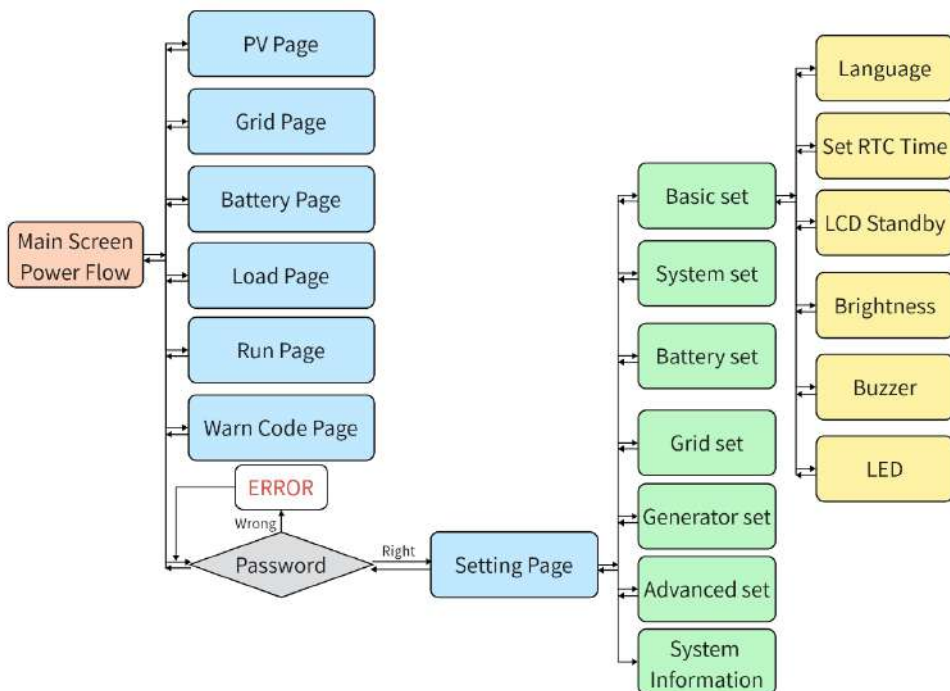

3.2 REAL-TIME INFORMATION PAGE

• PV PAGE

PV		↑
DC Voltage 1	0.0V	↶
DC Current 1	0.00A	⬆
DC Voltage 2	0.0V	⬆
DC Current 2	0.00A	⬆
DC Power 1	0W	⬆
DC Power 2	0W	⬆
E-PV-Day	0.0kWh	⬆
E-PV-Month	0.0kWh	⬆
E-PV-Year	0.0kWh	⬆
E-PV-All	0.0kWh	✓

This is **PV** Page, one page in total.

① Real-time data: It can display the two-channel DC voltage, current, and power in real time, and simultaneously display the current day, current month, current year, and cumulative power generation.

② Button: The right area of the screen is the button area, the top one to return to the home page, next to return to the previous page button, page-up button, page-down button, save button. When the button turns transparent, it means untouchable.

• GRID PAGE

Grid		↑
Grid Voltage	0.0V	↶
Grid Current	0.00A	⬆
Grid Frequency	0.00Hz	⬆
Output Power	0W	⬆
Reactive Power	0W	⬆
Power Factor	0.000	⬆
Grid Power Status	Sell	⬆
Meter Power	0W	⬆
Meter COM Status	Failure	✓

1/2

Grid		↑
E-Buy-Day	0.0kWh	↶
E-Buy-Month	0.0kWh	⬆
E-Buy-Year	0.0kWh	⬆
E-Buy-All	0.0kWh	⬆
E-Sell-Day	0.0kWh	⬆
E-Sell-Month	0.0kWh	⬆
E-Sell-Year	0.0kWh	⬆
E-Sell-All	0.0kWh	✓

2/2

This is **Grid** Page, two pages in total. The number of pages is displayed in the lower left corner.

① Real-time data: Real-time display of grid voltage, current, AC output power and reactive power, power factor, meter power, display of grid frequency, status and meter COM status, statistics of the day, month, year, and the cumulative amount of bought/sold energy.

② Grid Power Status: Balance; Sell; Buy.

③ Meter COM Status: Failure; OK.

• BATTERY PAGE

Battery		↑
Battery Voltage	0.00V	↶
Battery Current	0.00A	⬆
Battery Power	0W	⬆
Battery working Status	Discharge	⬆
Battery Test Status	Both allowed	⬆
BMS COM Status	OK	⬆
BMS Temperature	0.0°C	⬆
BMS Max Charge Current	0.00A	⬆
BMS Max Discharge Current	0.00A	✓

1/2

Battery		↑
E-Charging-Day	0.0kWh	↶
E-Charging-Month	0.0kWh	⬆
E-Charging-Year	0.0kWh	⬆
E-Charging-All	0.0kWh	⬆
E-Discharging-Day	0.0kWh	⬆
E-Discharging-Month	0.0kWh	⬆
E-Discharging-Year	0.0kWh	⬆
E-Discharging-All	0.0kWh	✓

2/2

This is **Battery** Page, two pages in total. The number of pages is displayed in the lower left corner.

- ① Real-time data: Real-time display of battery voltage, current, power, power, working status, detection status, BMS COM status, temperature, Max. charging and discharging current, and statistic of the day, month, year, and the cumulative amount of charged/discharged energy.
- ② Battery working Status: Standby; Charge; Discharge.
- ③ Battery Test Status: Disconnect; Charging allowed; Both allowed; Discharging allowed.
- ④ BMS COM Status: Failure; OK.

• **LOAD PAGE**

Load		🏠
Back-Up Voltage	0.0V	↶
Back-Up Current	0.00A	⬆
Back-Up Power	0W	⬇
E-Load-Day	0.0kWh	⬇
E-Load-Month	0.0kWh	⬇
E-Load-Year	0.0kWh	⬇
E-Load-All	0.0kWh	✓

This is **Load** Page, one page in total.

① Real-time data: Real-time display of load voltage, current, power consumption, statistics of the day, month, year, and the cumulative amount of consumed energy.

• **GEN PAGE**

Gen		🏠
Gen Voltage	0.0V	↶
Gen Current	0.00A	⬆
Gen Power	0W	⬇
Gen Frequency	0.00Hz	✓

This is **GEN** Page, one page in total.

① Real-time data: Real-time display of the voltage, current, power, frequency of the GEN.

• **RUN PAGE**

Load	Grid	Inverter	🏠
0W 0.0V 0W	0W 0.0V 0W	0W 0.0V 0W	↶
Battery	PV1	PV2	⬆
0W 0.00V 0.00A	0W 0.0V 0.00A	0W 0.0V 0.00A	⬇
			✓

This is **Run** Page, one page in total.

① Real-time data: Real-time display of the voltage and power of the load, the grid, the inverter output, the battery, and the two PVs.

• ERROR CODE PAGE

Error Code			↑
No	Time	Error Code	
01	20-00-00 00:00:00	W_1:1:Under Ugrid	↶
02	20-00-00 00:00:00	W_1:3:Under Fr	⬆
03	20-00-00 00:00:00	F_1_15:Remote shutdown	⬇
04	20-00-00 00:00:00	W_1:5:Under Upv	⬇
05	20-00-00 00:00:00	W_1:1:Under Ugrid	⬆
05	20-00-00 00:00:00	W_1:3:Under Fr	⬇
07	20-00-00 00:00:00	W_1:5:Under Upv	⬇
08	20-00-00 00:00:00	F_1_15:Remote shutdown	⬆
09	20-00-00 00:00:00	W_1:1:Under Ugrid	⬆
10	20-00-00 00:00:00	W_1:3:Under Fr	⬆
11	20-00-00 00:00:00	W_1:5:Under Upv	✓

1/9

This is **Error Code** Page, nine pages in total. The number of pages is displayed in the lower left corner.

① Real-time data: Real-time display of latest alarms (up to 99, 1 page stores 11), the latest is displayed at top, and it doesn't show if there is none. Specific contents include serial number, alarm time, corresponding fault codes.

3.3 PASSWORD ENTER PAGE

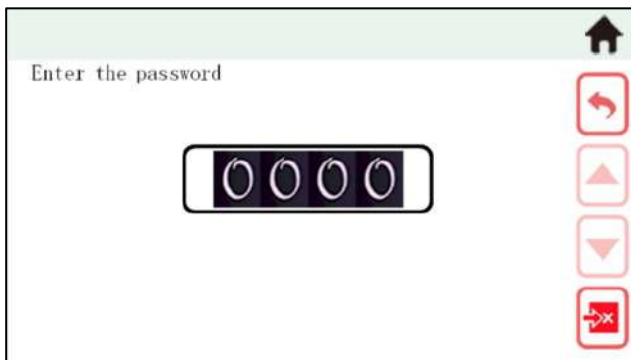

This is **Password Enter** Page, you need to enter the password correctly before entering the Setting Page.

- ① The default password is 1234.
- ② If the password is wrong, the entry icon in the lower right corner turns red, the door closes and an "X" appears; if the password is correct, the entry icon in the lower right corner turns green and the door opens.
- ③ If the password is correct, you can enter the setting page by clicking on the "door icon". If you click on the wrong password, "ERROR" will pop up, and you can only go back to the home page or the previous page by clicking on the button, and then go back to the password page to re-enter.
- ④ When the settings are changed and you return to the main page, the password will be cleared automatically.



This is **Keyboard Input** Page.

① "0-9" is used to input numbers, "." is used to input decimal, "+/-" is used to switch between positive and negative values, "←" is used to delete, "Esc" is used to quit or cancel input, "OK" is used to confirm.

3.4 SETTING PAGE

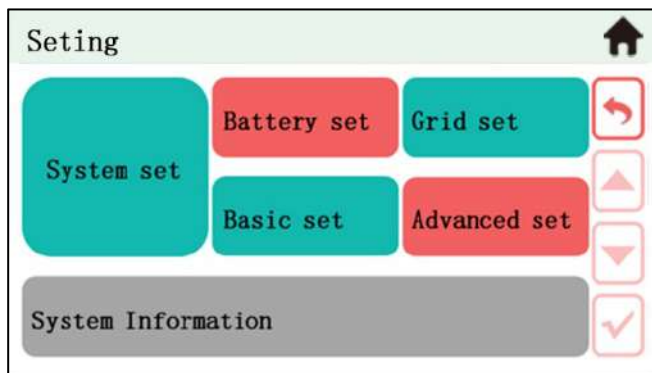

This is **Setting** Page, six buttons in total.
 ① System set: switch on/off; anti-reflux source; max. power selling; PV energy mode; charging and discharging periods, power, battery SOC, voltage settings.
 ② Battery set: Protocol Selection; Discharge Protection; BAT Activation Mode; Equal Charge Configuration; Float Charge Configuration.

- ③ Grid set: frequency selection; upper and lower limits of grid voltage; reconnection time.
- ④ Basic set: language; time; standby; brightness; buzzer; LED.
- ⑤ Advanced set: battery paralleling; forced off-grid mode; PCS paralleling address; PCS paralleling quantity; active/reactive power adjustment; power factor adjustment; PV shadow scanning; islanding protection; low-voltage ride-through; clearing overload faults.
- ⑥ System information: rated output power; FM version of LCD; program version of STM32, DSP_slave/master, CPLD; startup countdown time.

3.5 SYSTEM INFORMATION PAGE

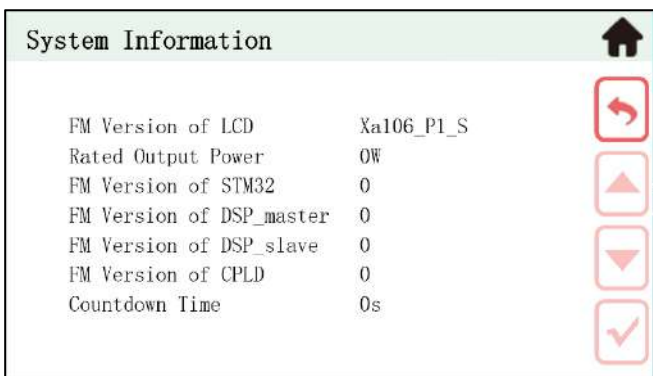

This is **System Information** Page, one page in total.
 ① Real-time data: Real-time display of rated output power; FM version of LCD; program version of STM32, DSP slave/master, CPLD; startup countdown time.

3.6 SYSTEM SET PAGE

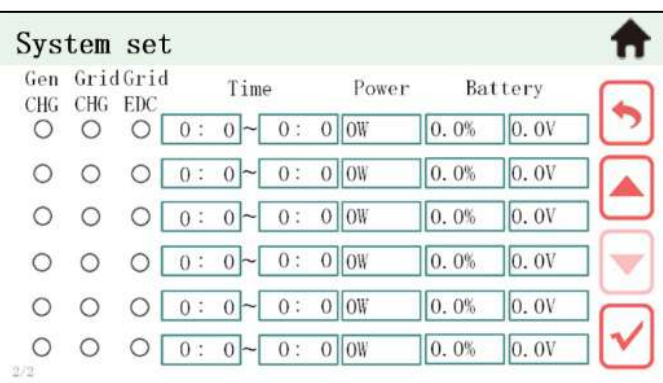
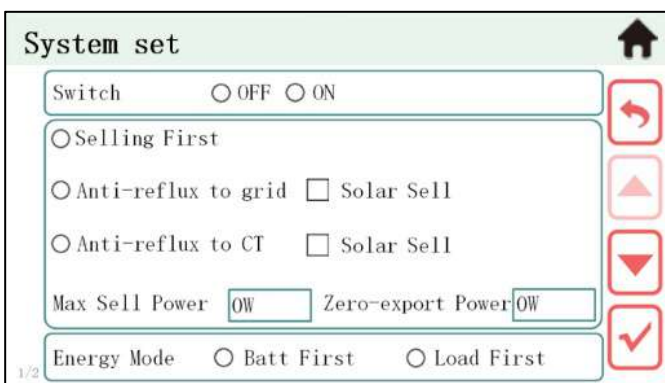

This is **System Set** Page, two pages in total. The number of pages is displayed in the lower left corner.

① **Switch:** Controls the power on and off of the inverter. means unselected, means selected.

② **Work Mode:**

i) **Selling First:** PV is used to power loads and battery, allowing the inverter to sell excess energy generated by the solar panels back to the grid. If it is during a discharging period, energy of battery can also be sold back to the grid. Prioritization of power supply sources for loads: PV>Grid>Battery.

ii) **Anti-reflux to grid:** The inverter only supplies power to the connected backup load. It neither supplies power to household loads nor sells power to the grid. The built-in CT will detect the power flowing back to the grid and will reduce the power of the inverter, only to supply local loads and charge for battery.

iii) **Anti-reflux to CT:** The inverter supplies power to connected backup loads and household loads. If PV power and battery power are insufficient, they will be supplied with grid power. The inverter won't sell power to the grid. In this mode, a CT is required and an external CT will detect the power flowing back to the grid and will reduce the power of the inverter, only to supply local and household loads, charge for battery.

③ **Solar Sell:** It is a special pattern in the Anti-reflux to grid or Anti-reflux to CT mode. If this pattern is on, excess energy can be sold back to the grid. At this time PV is prioritized for use as follows: loads, charging battery, grid. means off, means on.

④ **Max Sell Power:** The maximum output power allowed to flow into the grid.

⑤ **Zero-export Power:** The maximum amount of power flowing into the grid with the "Solar Sell" off.

⑥ **Energy Mode:** Prioritization of PV energy supply.

i) **Batt First:** PV energy supply is first used to charge the battery and then used to power the load. If the PV energy is insufficient, the grid will supply both the battery and the load.

ii) **Load First:** PV energy supply is first used to power the load and then used to charge the battery. If the PV energy is insufficient, the grid will supply both the battery and the load.

Note: If operating on off-grid status, the PV energy mode is always load first.

⑦ **Charging and Discharging Periods:** Up to six charging and discharging time periods can be set, click the circle to select charging(CHG) and discharging(EDC) mode, solid circle means selected. For convenience, hours and minutes are set separately, click on the input box and enter with the keyboard, set the start time first and then set the end time. Moreover, charge and discharge power can be set, as well as battery cut-off SOC and voltage. In order to avoid generating program conflicts, the two time periods front and rear are configured with a continuous relationship, where the end time of the previous period is the start time of the subsequent period.

In addition, if the battery protocol is a Pb Acid, the battery cut-off SOC item can only be set to 0% or 100% when setting the period parameter. Charging needs to be set to 100% and discharging needs to be set to 0%.

⑧ **GEN Charge:** utilize diesel generator to charge the battery in a time period.

3.7 BATTERY SET PAGE

Battery set

Protocol Setting -- Pb Acid

Discharging Protection

	On-grid SOC	Off-grid SOC	Voltage
Cut-off	0%	0%	0.00V
Restored	0%	0%	0.00V
Discharge Max. Current	0.00A		

Active BAT Mode enable

1/2

Protocol Setting

Pb Acid CAN-Bus-PROTO-PYLON-v1.3

Battery set

U-Equal Charge	0.00V
I-Equal Charge	0.00A
U-Float Charge	0.00V
I-Float Charge	0.00A
T-Float Charge	0min

Grid Charge Reserve SOC 0%

2/2

This is **Battery Set** Page, two pages in total. The number of pages is displayed in the lower left corner.

① **Protocol Setting:** Select battery BMS protocol, currently supports Pb Acid and CAN-Bus-PROTO-PYLON-v1.3. Click to sub-page to select, and click save, back to Battery set page.

② **Discharging Protection:**

i) Cut-off: Set the battery discharge to stop only when it reaches the given conditions (battery SOC and voltage in on-grid/off-grid state).

ii) Restored: Set the power supply to load to restore only when it reaches the given conditions (battery SOC and voltage in on-grid/off-grid state).

iii) Discharge Max. Current: The maximum value of current allowed to be reached in the discharging state of the battery.

③ **Active BAT Mode enable:** Restore the battery from its over-discharged state by slowly charging it from the PV array or the grid. This feature needs to be set up when the inverter is down.

④ **Equal Charge:** Battery equal charge voltage and current can be set.

⑤ **Float Charge:** Battery float charge voltage, current and time (in minutes) can be set.

⑥ **Grid Charge:** The inverter draws energy from the grid to charge the battery, allowing the battery's capacity to reach Reserve SOC.

3.8 GRID SET PAGE

Grid set

Grid Frequency 50Hz 60Hz

Grid Voltage Upper limit 0.0V

Grid Voltage Lower limit 0.0V

Grid Frequency Up limit 0.00Hz

Grid Frequency Low limit 0.00Hz

Grid Reconnect delay 0

This is **Grid Set** Page, one page in total.

① Frequency select: please select your local grid frequency, you can choose 50Hz, 60Hz.

② Grid Voltage: Upper and lower grid voltage limits can be set.

③ Grid Frequency: Upper and lower grid frequency limits can be set.

④ Grid Reconnect delay: The reconnection time can be set in the on-grid state.

The grid frequency needs to be selected when the inverter is down, and the inverter needs to be powered back on after the selection is completed.

3.9 BASIC SET PAGE

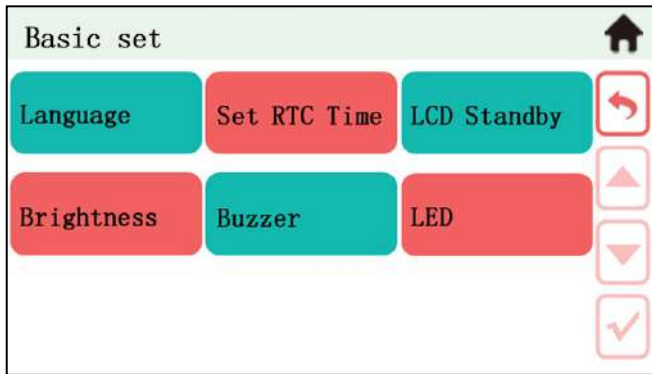

This is **Basic Set** Page, six buttons in total.

- ①Language: LCD language can be set, switching between 中文 and English.
- ②Set RTC Time: The RTC time can be changed.
- ③LCD Standby: Screen standby time can be set, that is to say, how long there is no touch to apply to the screen, its brightness is automatically reduced to lowest. The settable range is 1~240s.
- ④Brightness: The current brightness of the screen can be set. The settable range is 1~100%.
- ⑤Buzzer: Buzzer can be set to sound or not when touching.
- ⑥LED: Support LED night mode function, you can set whether to enable or not and time period.

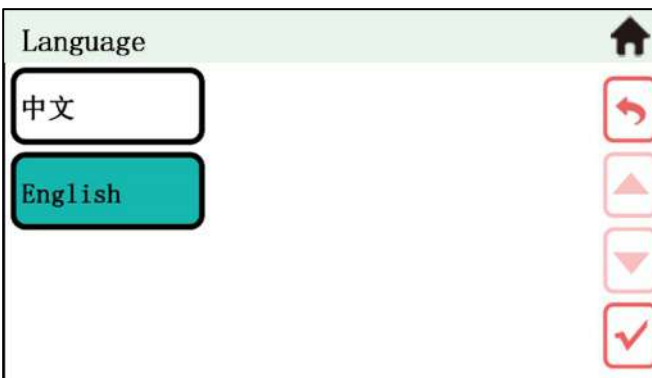

This is **Language** Page.

- ①中文 and English languages are supported.
- ②The current language is displayed in real time by the color of the option block, blue is selected, white is not.
- ③When you change the language, you can judge whether the click is effective or not by whether the color of the option block changes to blue, and then click Save.
- ④After changing the language, it will take a few seconds for all the text to be changed to the new language, so please don't click it too often.

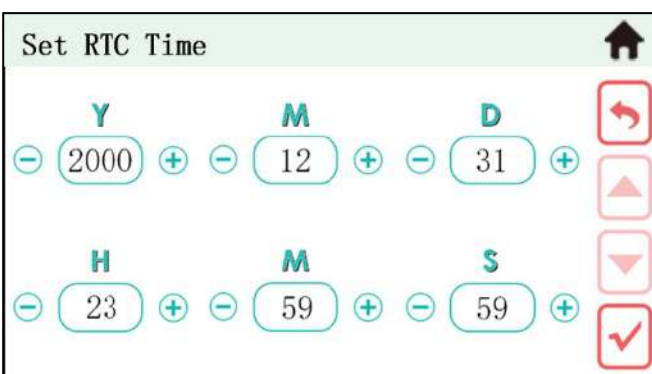

This is **Set RTC Time** Page.

- ①RTC time can be set to meet the needs of different areas of use.
- ②For ease of operation, the year, month, day, hour, minute, and second are added and subtracted respectively. Y-M-D H:M:S means Year-Month-Day Hour: Minute: Second.
- ③After changing the time, you can return to the main page to see that the system time has been changed to the newly set time.

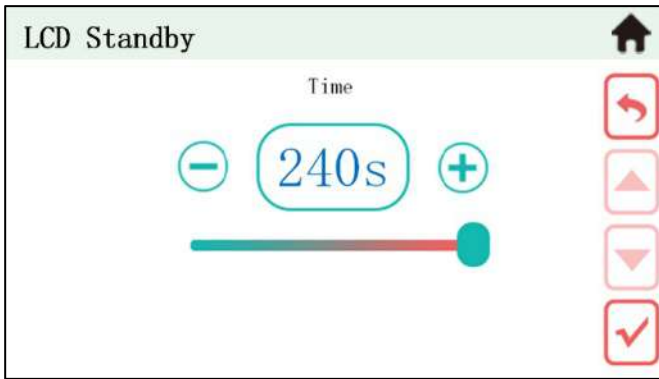

This is **LCD Standby** Page.

- ① Screen standby time can be set, that is to say, how long there is no touch to apply to the screen, its brightness is automatically reduced to lowest.
- ② There are two ways to adjust, clicking on the plus or minus icon or dragging the slider to adjust.
- ③ The settable range is 1~240s. The default value is 240s.

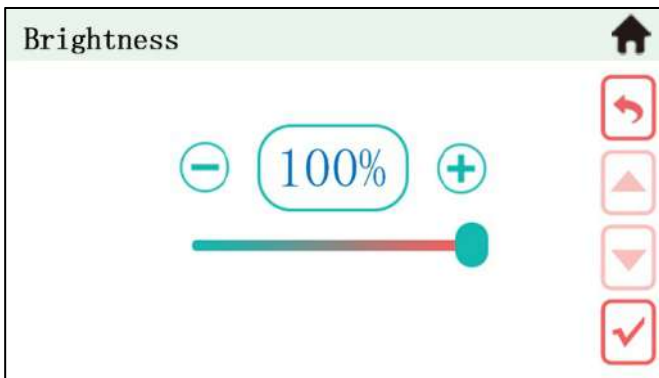

This is **Brightness** Page.

- ① The current brightness of the screen can be set to be displayed as a percentage of the maximum brightness.
- ② There are two ways to adjust, clicking on the plus or minus icon or dragging the slider to adjust.
- ③ The settable range is 1~100%. To protect the screen, upper and lower limits are set for the actual display brightness. The default value is 64%.

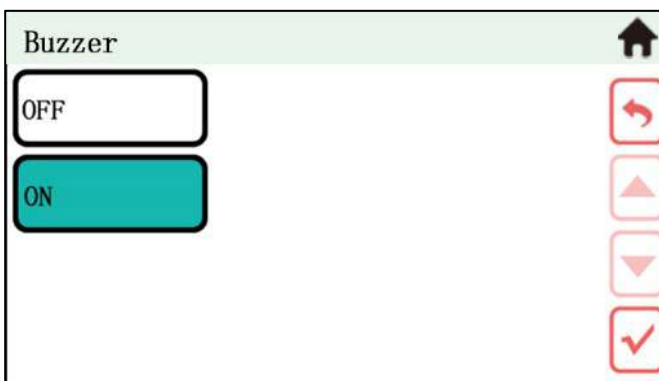

This is **Buzzer** Page.

- ① Buzzer can be set to sound or not when touching.
- ② The current buzzer setting is displayed in real time by the option block color, blue is the current buzzer selected state.
- ③ When changing the buzzer switch, you can judge whether the click is valid by whether the option box color changes to blue, and then click save setting.

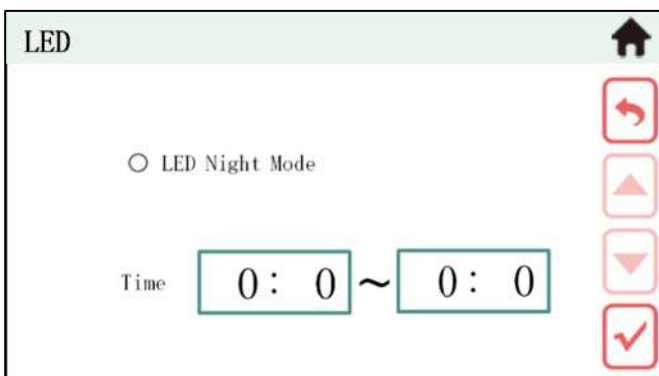

This is **LED** Page.

- ① For settings related to controlling the LED light off at night.
- ② You can set whether to enable the LED night mode or not.
- ③ You can set the time period to use the night mode and enable the control function, to realize automatic control of LED light off.

3.10 ADVANCED SET PAGE

Advanced set🏠

- Force Off-grid Mode
- Only PV Off-grid enable
- Gen Signal
- PCS Parallel address
- PCS Parallel quantity
- CT Ratio

↶
▲
▼
✓

1/3

Advanced set🏠

- Overload Reset
- Smart Load Output
- Protection SOC Voltage
- Restored
- Active Power
- Reactive Power
- Power Factor

↶
▲
▼
✓

2/3

Advanced set🏠

- Factory Reset
- Default Reset

↶
▲
▼
✓

3/3

This is **Advanced Set** Page, two pages in total. The number of pages is displayed in the lower left corner.

- ① **Force Off-grid Mode**: Use this function to force a switch to the off-grid state, which prioritizes power to the load in this mode.
- ② **Only PV off-grid enable**: Inverter In the off-grid state with only PV input, if this function is enabled, the machine can start to supply power to the load. This feature needs to be set up when the inverter is down.
- ③ **GEN Signal**: If this function is turned on, then when the power grid suddenly disappears, the inverter will send a dry contact signal to control the generator to start running; When the power grid returned to normal, the dry contact signal was disconnected and the generator stopped working.
- ④ **PCS Parallel**: Support PCS parallel function, you can set the address and quantity of parallel machine. (Multiple machines in parallel: the address of each machine must start from 1, consecutive and less than or equal to parallel quantity). This function needs to be set when the inverter is down, and the inverter needs to be powered back on after the setup is completed.
- ⑤ **Overload Reset**: After an alarm occurs, while other kinds of fault can be cleared automatically, only overload faults need to be cleared manually with this function. The operation way is to click on the hollow circle to change it to a solid circle, click on the Save button, and return to the Setting page automatically, then the overload fault is cleared successfully once. The next time you need to clear it, just repeat the operation above.
- ⑥ **Smart Load Output**: This mode utilizes the Gen input connection as an output witch only receives power when the battery SOC and Voltage is above a user programmable threshold. This feature needs to be set up when the inverter is down.

- ⑦ Power Regulation : Active power regulation, reactive power regulation and power factor regulation are available.
- ⑧ CT Ratio: Set CT Ratio.
- ⑨ Factory Reset: Reset all parameters of the inverter and reset the power generation data to zero.
- ⑩ Default Reset: Reset all parameters of the inverter without clearing the power generation data.

4

TROUBLE-
SHOOTINGS

4.1 Warning List

System Warning Code 1	Warning Event	Description	Solutions
0	Over Ugrid	The Grid Voltage is Higer than the setting value when the inverter is running	<ol style="list-style-type: none"> 1. Check the AC voltage is in the range of standard voltage inspecification; 2. Check whether grid AC cables are firmly and correctly connected; 3. If the error message still remains, please contact your installer.
1	Under Ugrid	The Grid Voltage is Lower than the setting value when the inverter is running	<ol style="list-style-type: none"> 1. Check the AC voltage is in the range of standard voltage inspecification; 2. Check whether grid AC cables are firmly and correctly connected; 3. If the error message still remains, please contact your installer.
2	Over Fr	The Grid Frequency is Higer than the setting value when the inverter is running	<ol style="list-style-type: none"> 1. Check the frequency is in the range of specification or not; 2. Check whether AC cables are firmly and correctly connected; 3. If the error message still remains, please contact your installer.
3	Under Fr	The Grid frequency is Lower than the setting value when the inverter is running	<ol style="list-style-type: none"> 1. Check the frequency is in the range of specification or not; 2. Check whether AC cables are firmly and correctly connected; 3. If the error message still remains, please contact your installer.
4	Line Check	The Grid is Loss when the inverter is running	<ol style="list-style-type: none"> 1. Check whether grid AC cables are firmly and correctly connected; 2. Restart the inverter 2-3 times; 3. If the fault still existing, please contact us for help.
5	Under Upv	The PV voltage is lower than 120V when turn on the PV switch	<ol style="list-style-type: none"> 1. Check the PV is in the range of specification or not; 2. Check whether PV cables are firmly and correctly connected; 3. If the error message still remains, please contact your installer.
6	Reserved		
7	Reserved		
8	Reserved		
9	Reserved		
10	Reserved		
11	Reserved		

12	Reserved		
13	Reserved		
14	Reserved		
15	Reserved		

System Warning Code 2	Warning Event	Description	Solutions
0	UBATTERY_LO W	The battery voltage is lower than 44V or lower than the SOC that you setting	<ol style="list-style-type: none"> 1. Check the battery voltage; 2. Check whether Battery cables are firmly and correctly connected; 3. Restart the inverter 2-3 times; 4. If the fault still existing, Please contact your installer.
1	UBATTERY_LOS S	The battery is lower than 25V	<ol style="list-style-type: none"> 1. Check the battery voltage; 2. Check whether Battery cables are firmly and correctly connected; 3. Restart the inverter 2-3 times; 4. If the fault still existing, Please contact your installer.
2	Reserved		
3	Reserved		
4	Fault FAN	The FAN isn't working	<ol style="list-style-type: none"> 1. Restart the inverter 2-3 times; 2. If the fault still existing, Please contact your installer.
5	Reserved		
6	Battery Transient under voltage	The battery voltage is lower than 40V at one moment	<ol style="list-style-type: none"> 1. Check the battery voltage; 2. Check whether Battery cables are firmly and correctly connected; 3. Restart the inverter 2-3 times; <p>If the fault still existing, Please contact your installer.</p>
7	Reserved		
8	Reserved		
9	DC Stop	The DC side isn't working	<ol style="list-style-type: none"> 1, The BUS voltage can't be built from PV or battery. 2. Check whether Battery cables are firmly and correctly connected; 3. Restart the inverter 2-3 times; 4. If the fault still existing, Please contact your installer.
10	Reserved		
11	Reserved		
12	Reserved		
13	Reserved		
14	Reserved		
15	Reserved		

4.2 Fault Reference Codes

System Fault Code 1	Fault Event	Description	Solutions
0	Under Upv1	The PV voltage is lower than 20V ,and the current is higher than 2A	<ol style="list-style-type: none"> 1. Check the PV is in the range of specification or not; 2. Check whether PV cables are firmly and correctly connected; 3. If the error message still remains, please contact your installer.
1	Over Ipv1	The PV current is higher than 30A	<p>DC side over current fault</p> <ol style="list-style-type: none"> 1. Check PV module connect and battery connect; 2. Turn off the DC switch and AC switch and then wait one minute, then turn on the DC/AC switch again; 3. If the error message still remains, please contact your installer.
2	Over Upv1	The PV voltage is higher than 500V	<ol style="list-style-type: none"> 1. Check the PV is in the range of specification or not; 2. Check whether PV cables are firmly and correctly connected; 3. If the error message still remains, please contact your installer.
3	Over Ipv2	The PV current is higher than 30A	<p>DC side over current fault</p> <ol style="list-style-type: none"> 1. Check PV module connect and battery connect; 2. Turn off the DC switch and AC switch and then wait one minute, then turn on the DC/AC switch again; 3. If the error message still remains, please contact your installer.
4	Over temp	The temperature is higher than 100°C	<ol style="list-style-type: none"> 1. Check whether the work environment temperature is too high; 2. Turn off the inverter for 10mins and restart; 3. If the fault still existing, please contact us for help.
5	Over Iac	AC over current fault	<p>AC side over current fault</p> <ol style="list-style-type: none"> 1. Please check whether the backup load power and common load power are within the range; 2. Restart and check whether it is in normal; 3. Check the backup load connected, make sure it is in allowed power range 4. If the fault still exists, please contact us for help 5. If the error message still remains, please contact your installer.
6	Over Ugrid	The Grid Voltage is	Grid voltage fault

		Higer than the setting value when the inverter isn't running	<ol style="list-style-type: none"> 1. Check the AC voltage is in the range of standard voltage inspecification; 2. Check whether grid AC cables are firmly and correctly connected; 3. If the error message still remains, please contact your installer.
7	Over Fr	The Grid Frequency is Higer than the setting value when the inverter isn't running	<p>Grid frequency out of range</p> <ol style="list-style-type: none"> 1. Check the frequency is in the range of specification or not; 2. Check whether AC cables are firmly and correctly connected; 3. If the error message still remains, please contact your installer.
8	Under Backup	The backup is connected with the Grid	<ol style="list-style-type: none"> 1. Check the backup terminal; 2. Detect the backup voltage with the multimeter; 3. Restart the inverter 2-3 times; 4. If the fault still existing, please contact us for help.
9	Over Ubus	The BUS Voltage is Higer than 560V	<ol style="list-style-type: none"> 1. check the total power of the inverter; 2. Restart the inverter 2-3 times; 3. if the fault still existing, please contact us for help.
10	Over Ileak	AC leakage current fault	<p>Leakage current fault</p> <ol style="list-style-type: none"> 1. Check the PV side cable ground connection; 2. Restart the inverter 2-3 times; 3. If the fault still existing, please contact us for help.
11	Fault Relay	The Relay isn't working	<ol style="list-style-type: none"> 1. Restart the inverter 2-3 times; 2. If the fault still existing, please contact us for help.
12	Fault GFD	DC insulation failure	<p>PV isolation resistance is too low</p> <ol style="list-style-type: none"> 1. Check the connection of PV panels and inverter is firmly and correctly; 2. Check whether the PE cable of inverter is connected to ground; 3. If the error message still remains, please contact your installer.
13	Over Backup Voltage	The Backup Voltage is high	<ol style="list-style-type: none"> 1. Check the backup terminal; Detect the backup voltage with the multimeter; 2. Restart the inverter 2-3 times; 3. If the fault still existing, please contact us for help.
14	XINT Iac	The inverter current is high and touch the protection.	<ol style="list-style-type: none"> 1. check the power of the backup load; 2. Restart the inverter 2-3 times; 3. If the fault still existing, please contact us for help.
15	Remote Shutdown	Turn off the inverter	<ol style="list-style-type: none"> 1. Check the other fault code of the inverter and according to the solution to solve the problem.

			<ol style="list-style-type: none"> 2. Restart the inverter 2-3 times; 3. If the fault still existing, please contact us for help.
--	--	--	---

System Fault Code 2	Fault Event	Description	Solutions
0	Fault SPI	The upper computer communicates with the lower computer fault	<ol style="list-style-type: none"> 1. Restart the inverter 2-3 times; 2. if the fault still existing, please contact us for help.
1	Under Ugrid	The Grid Voltage is Lower than the setting value when the inverter isn't running	<p>Grid voltage fault</p> <ol style="list-style-type: none"> 1. Check the AC voltage is in the range of standard voltage inspecification; 2. Check whether grid AC cables are firmly and correctly connected; 3. If the error message still remains, please contact your installer.
2	Under Fr	The Grid Frequency is Lower than the setting value when the inverter isn't running	<p>Grid frequency out of range</p> <ol style="list-style-type: none"> 1. Check the frequency is in the range of specification or not; 2. Check whether AC cables are firmly and correctly connected; 3. If the error message still remains, please contact your installer.
3	Under Upv2	The PV voltage is lower than 20V ,and the current is higher than 2A	<ol style="list-style-type: none"> 1. Check the PV is in the range of specification or not; 2. Check whether PV cables are firmly and correctly connected; 3. If the error message still remains, please contact your installer.
4	Over Upv2	The PV voltage is higher than 500V	<ol style="list-style-type: none"> 1. Check the PV is in the range of specification or not; 2. Check whether PV cables are firmly and correctly connected; 3. If the error message still remains, please contact your installer.
5	Reserved		
6	Under Ubus	The BUS Voltage is Lower than 300V	<ol style="list-style-type: none"> 1. check the total power of the inverter; 2. Restart the inverter 2-3 times; 3. If the fault still existing, please contact us for help.
7	Reserved		
8	Fault Temper	The Temper is fault	<ol style="list-style-type: none"> 1. Check whether the work environment temperature is too high or too low; 2. Turn off the inverter for 10mins and restart; 3. If the fault still existing, please contact us

			for help.
9	Over Load		1. check the total power of the inverter; 2. Restart the inverter 2-3 times; 3. If the fault still existing, please contact us for help.
10	Reserved		
11	Parallel Data Loss	Parallel Data Loss	1. When in parallel mode, check the parallel communication cable connection and hybrid inverter communication address setting; 2, Restart the inverter 2-3 times; 3. If the fault still exists, please contact us for help.
12	Parallel Phase Loss	Parallel Phase Loss	1. When in parallel mode, check the parallel communication cable connection and hybrid inverter communication address setting; 2. Restart the inverter 2-3 times; 3. If the fault still exists, please contact us for help.
13	Parallel Stop	Parallel system stop	1. Check the hybrid inverter work status. According to the fault code to solve the problem. 2. If the fault still existing, please contact us for help.
14	XINT Ipv	The PV boost current is high and touch the protection.	1. check the PV voltage and the power of the backup load; 2. Restart the inverter 2-3 times; 3. If the fault still existing, please contact us for help.
15	Reserved		

System Fault Code 3	Fault Event	Description	Solutions
0	UBUS_OVER	The BUS Voltage is Higer than 560V	1. check the total power of the inverter; 2. Restart the inverter 2-3 times; 3. If the fault still existing, please contact us for help.
1	UBUS_LOW	The BUS Voltage is Lower than 300V	1. check the total power of the inverter; 2. Restart the inverter 2-3 times; 3. If the fault still existing, please contact us for help.
2	UBATTERY_OVER	The Battery Voltage is Higer than 60V	1. Check the battery voltage; 2. Restart the inverter 2-3 times; 3. If the fault still existing, please contact us for help.
3	Reserved		
4	ILLC_OVER	The LLC current is high	1. check the total power of the inverter include the charging and the discharging current;

			<ol style="list-style-type: none"> Restart the inverter 2-3 times; If the fault still existing, please contact us for help.
5	IBuckBoost_OV ER	The Buck-boost voltage is high and touch the protection	<ol style="list-style-type: none"> check the total power of the inverter include the charging and the discharging current; Restart the inverter 2-3 times; If the fault still existing, please contact us for help.
6	ULLC_OVER	The LLC voltage is high and touch the protection	<ol style="list-style-type: none"> check the total power of the inverter include the charging and the discharging current; Check the battery voltage; Restart the inverter 2-3 times; If the fault still existing, please contact us for help.
7	Fault data SPI	The upper computer communicates with the lower computer fault	<ol style="list-style-type: none"> Restart the inverter 2-3 times; If the fault still existing, please contact us for help.
8	Over time SPI	The upper computer communicates with the lower computer fault	<ol style="list-style-type: none"> Restart the inverter 2-3 times; If the fault still existing, please contact us for help.
9	Over Ibat	The battery current is higher than 1.5 multiples of the setting value	<ol style="list-style-type: none"> check the discharging current that you setting; check the total power of the inverter; If the fault still existing, please contact us for help.
10	Reserved		
11	Reserved		
12	Reserved		
13	Reserved		
14	ILLC_XINT	The LLC current is high and touch the protection	<ol style="list-style-type: none"> check the total power of the inverter include the charging and the discharging current; Restart the inverter 2-3 times; If the fault still existing, please contact us for help.
15	IBuckBoost_XIN T	The Buck-boost current is high and touch the protection	<ol style="list-style-type: none"> check the total power of the inverter include the charging and the discharging current; Restart the inverter 2-3 times; If the fault still existing, please contact us for help.

5.1 DISCLAIMER

The hybrid inverters are transported, used and operated under environmental and electrical conditions. We have the right not providing after-sales services or assistance under following conditions:

- Inverter is damaged during transferring.
- The inverter is out of warranty and no extended warranty is required.
- Inverter is installed, refitted or operated in improper ways without authority from us.
- Inverter is installed or used under improper environment or technical condition mentioned in this user manual, without authority from us.
- Installation or configuration of the inverter does not follow requirements mentioned in this user manual.
 - The inverter is installed or operated against the requirements or warnings that are mentioned in this user manual.
- Inverter is broken or damaged by any force majeure like lightning, earthquake, fire hazard, storm and volcanic eruption etc.
- Inverter is disassembled, changed or updated on software or hardware without authority from us.
- Inverter is installed, used or operated against any related items in international or local policies or regulations.
- Any non-compatible batteries, solar panels, loads or other devices connected to Hybrid inverter system



We will keep right to explain all the contents in this user manual.

*Maintenance

The inverter requires periodically maintenance, details as below:



Make sure inverter is totally isolated from all DC and AC power for at least 5 mins before maintenance

Heat sink: please use clean towel to clean up heat sink once a year.

Torque: please use torque wrench to tighten AC and battery wiring connection once a year.

DC switch: check DC switch regularly, active the DC switch 10 times in a row once a year.

Operating DC switch will clean contacts and extend lifespan of DC switch.

Appendix: Protection Category Definition

Environment Category Definition

Environment Condition	Ambient Temperature	Relative Humidity	Applied to
Outdoor	-20~+50°C	4%~100%	PD3
Indoor Unconditioned	-20~+50°C	5%~95%	PD3
Indoor Conditioned	0~+40°C	5%~85%	PD2

Pollution Degree Definition

Pollution Degree I	No pollution or only dry, non-conductive pollution occurs. The pollution has no influence
Pollution Degree I	Normally only non-conductive pollution occurs. Occasionally, however, a temporary conductivity caused by condensation must be expected.
Pollution Degree II	Conductive pollution occurs, or dry, non-conductive pollution occurs, which becomes conductive due to condensation which is expected.
Pollution Degree IV	Persistent conductive pollution occurs, for example, the pollution caused by conductive dust, rain and snow.

5.2 TECHNICAL PARAMETERS

MODEL	META 6kW SP	META 8kW SP
PV input		
Max input voltage	500 V	
Isc PV (absolute Max.) (A)	22.5/22.5	37.5/22.5
Max input current(A)	18A/18A	30A/18A
Number of MPPT channels	2	
MPPT Range (Vdc)	150~450	
Vdc range @ full power (Vdc)	240~425	
Max input PV power (VA)	12000	16000
Battery (charge/discharge)		
Battery type	Li-ion/Lead-acid	
Rated battery voltage	48V(44-57V)	
Max charge/discharge Current(A)	135	190
Max charge/discharge Power(W)	6000	8000
AC Grid (input and output)		
Rated AC Voltage (VAC)	220/230(single phase)	
Rated Frequency (Hz)	50/60	
Max.output current (A)	30	40
Max. output Power (W)	6000	8000
Max. Apparent Power (VA)	6600	8800
Power factor(adjustable)	1~(0.8 leading to 0.8 lagging)	
AC Load output (stand alone)		
Rated Voltage (VAC)	220/230(single phase)	
Rated Frequency (Hz)	50/60	
Rated Current(A)	30	40
Max. output power (W)	6000	8000
Overload Capability (off grid)	>200% for 15 sec	
Output Power Factor(off grid)	1~(0.8 leading to 0.8 lagging)	
Output Current Harmonic Distortion	THD<3%(Nonlinear load); THD<1.5%(Linear load)	
Others		
Protective class	Class I	
Temperature (°C)	-25°C~+60°C	
Inverter Isolation	Non-isolated PV- AC	
	High frequency isolated(Battery Side)	
Overvoltage category	OVC III (AC Main), OVC II (PV)	
Dimensions,D*W*H (mm)	198*427*554	
Weight (kg)	20	
Altitude	2000m	